

26. ACCESSORIES

Battery Modules

Two pre-assembled battery modules with a single 12V battery are available for different buffer times. As an option, the mounting brackets are also available without batteries. This option offers more flexibility in selecting an appropriate battery or can save shipping and logistic costs. See individual datasheets for detailed information.

	UZK12.071	UZK12.261	
Battery type	Standard version 12V, 7Ah	High current version 12V, 26Ah	VRLA lead-acid maintenance free battery
Service life	3 to 5years	10 to 12years	According to EUROBAT guideline
Dimensions	155x124x112mm	214x179x158mm	Width x height x depth
Weight	3.2kg	9.9kg	
DIN-Rail mountable	yes	no	
Order number	UZK12.071 UZO12.07 UZB12.071	UZK12.261 UZO12.26 UZB12.261	Battery module Mounting bracket without battery Replacement battery only

Fig. 26-1 **UZK12.071**



Fig. 26-2 **UZK12.261**



ZM1.WALL Wall / Panel mounting bracket

This bracket is used to mount the DC-UPS units onto a flat surface without utilizing a DIN-Rail. The two aluminum brackets and the black plastic slider of the DC-UPS have to be removed so that the two surface brackets can be mounted.

Fig. 26-3 **ZM1.WALL Wall / Panel Mounting Bracket**

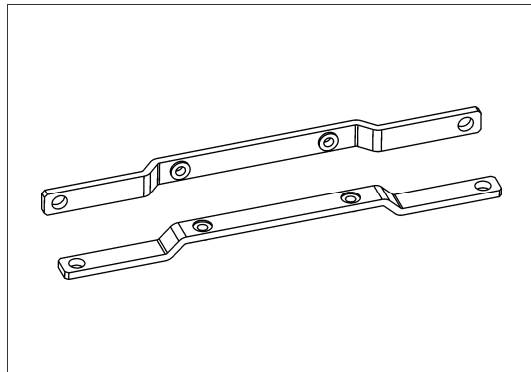

Fig. 26-4 **Assembled Wall / Panel Mounting Bracket**

